



Lanai Shower System
Model #1089-BN & 1089-CH

PW-91089-7325BRN & PW-91089-7325CP

Owner's Manual



Please Read The Following Instructions
COMPLETELY Before Beginning!

Our goal is to ensure your installation goes smoothly and safely. Please read these instructions carefully and follow recommendations for plumbing and mounting. After reading instructions, if you determine you do not have the necessary skills and/or tools, we recommend that a licensed plumbing contractor complete the installation.

If you encounter any problems during installation
PLEASE VISIT CUSTOMER SUPPORT AT
WWW.PULSESHOWERSPAS.COM
Before returning your Shower System to the store

You Will Need The Following Tools

Soft pencil or felt pen to mark tile

4mm & 5mm allen wrench

Safety glasses

Tape measure

Level

Channel locks or adjustable wrench

Drill (preferably cordless)

Masonry drill bit

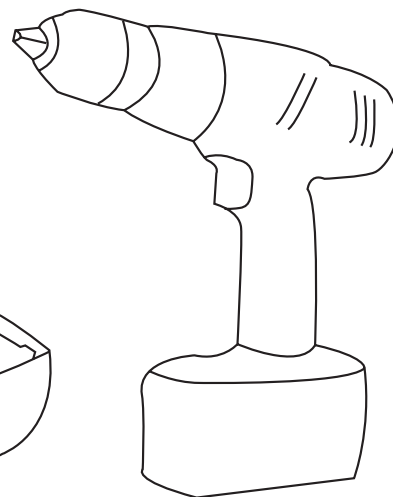
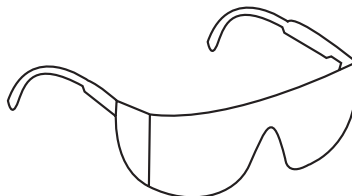
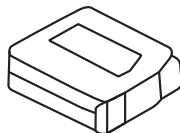
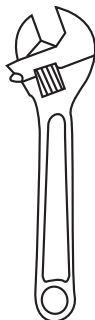

Parts Legend

- | | | |
|---------------------------|----------------------------|-----------------------|
| 1. Anchors.....8 | 11. Escutcheon | 21. Handshower |
| 2. Plumber's Tape | 12. Allen Wrench 2.5/3mm | 22. Handshower Hose |
| 3. Check Valve.....2 | 13. Set Screw | 23. Handshower Holder |
| 4. Nipple | 14. Set Screw M5x5mm.....2 | 24. Diverter |
| 5. Flow Restrictor | 15. Top T | 25. Cover Mount |
| 6. Big Hex Wrench 8mm | 16. Shower Arm | 26. Set Screw |
| 7. Gasket | 17. Washer.....3 | 27. Lower Mount Plate |
| 8. Set Screw M6x8mm.....2 | 18. Showerhead | 28. 3M Tape |
| 9. Inlet Fitting | 19. Shower Pipe | 29. Lube |
| 10. Screws M4x25mm.....8 | 20. Body Jets | |

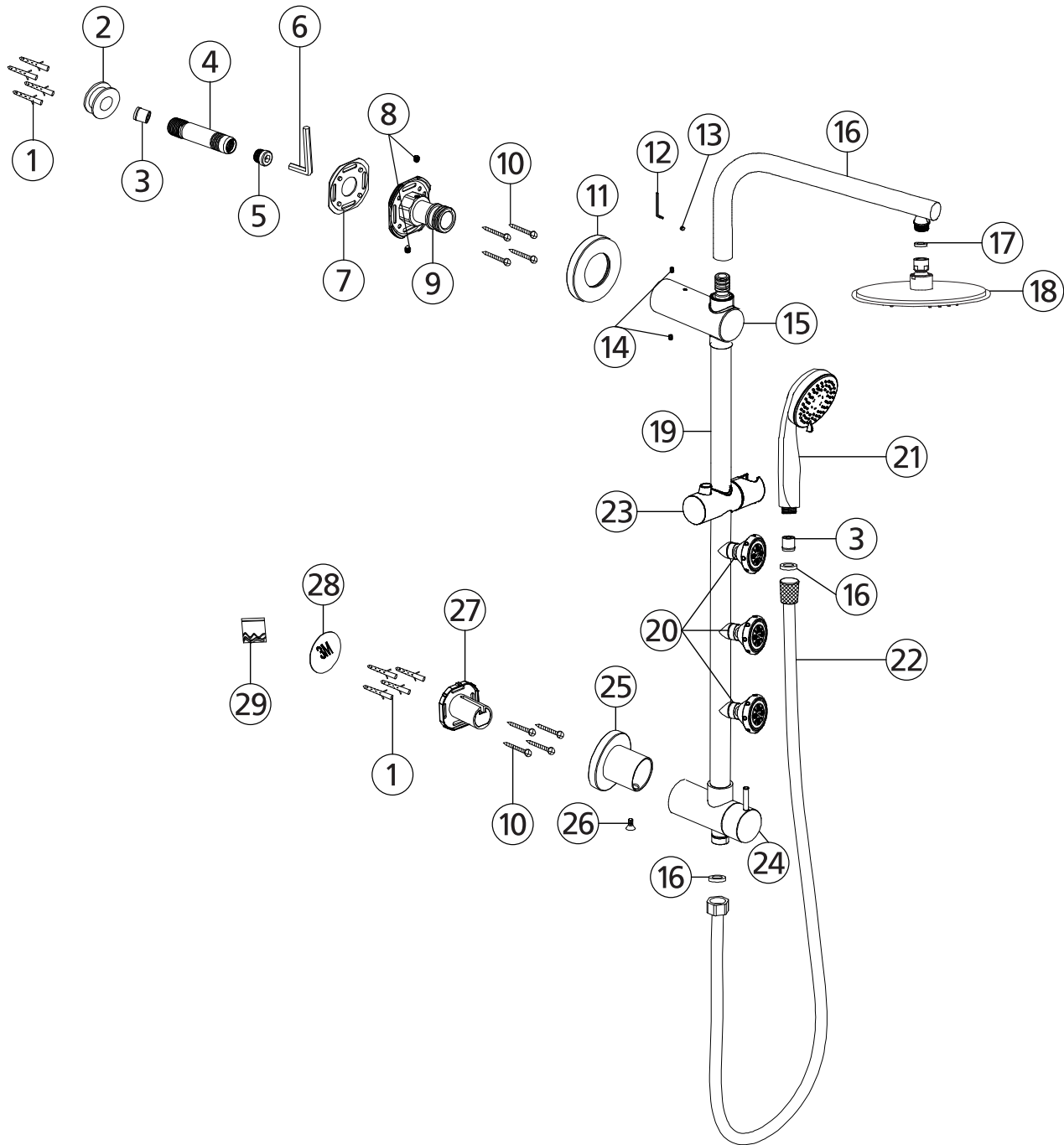

BEFORE YOU BEGIN

Measure the following to ensure your Shower System will fit properly.

New Construction

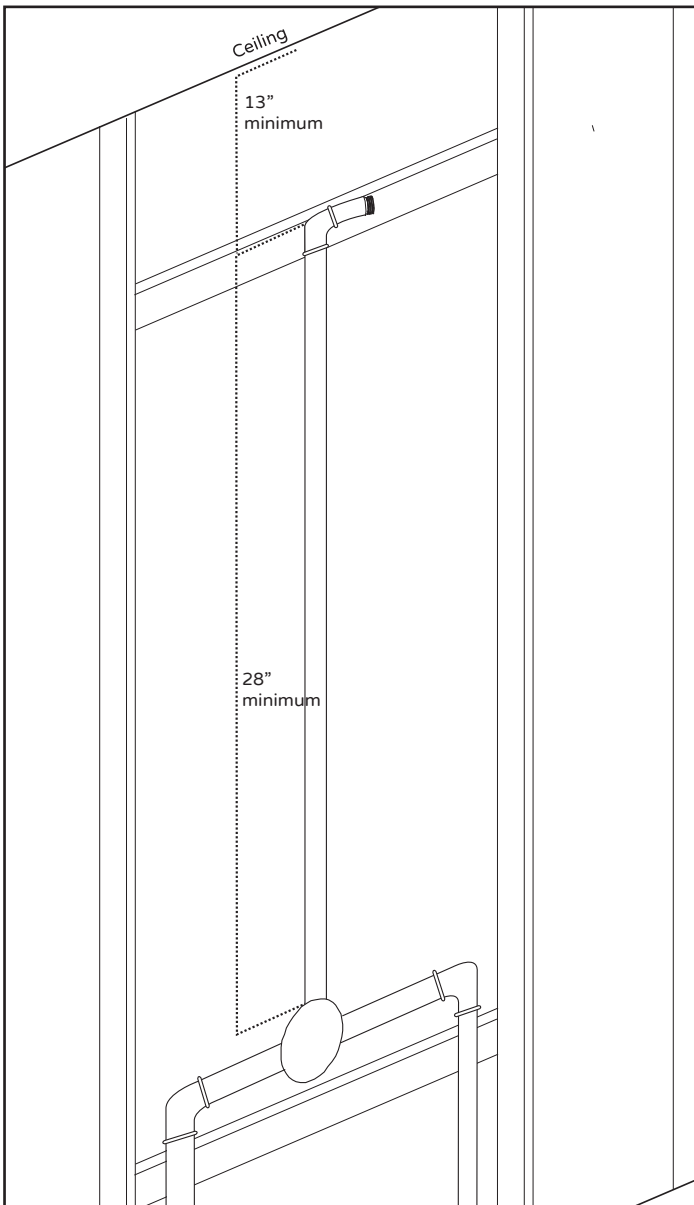

Make sure distance from water outlet and mixing valve trim (NOT INCLUDED) is a minimum 28" or more.

Make sure the distance from the water outlet and the ceiling is a minimum of 13" or more.

Retrofit

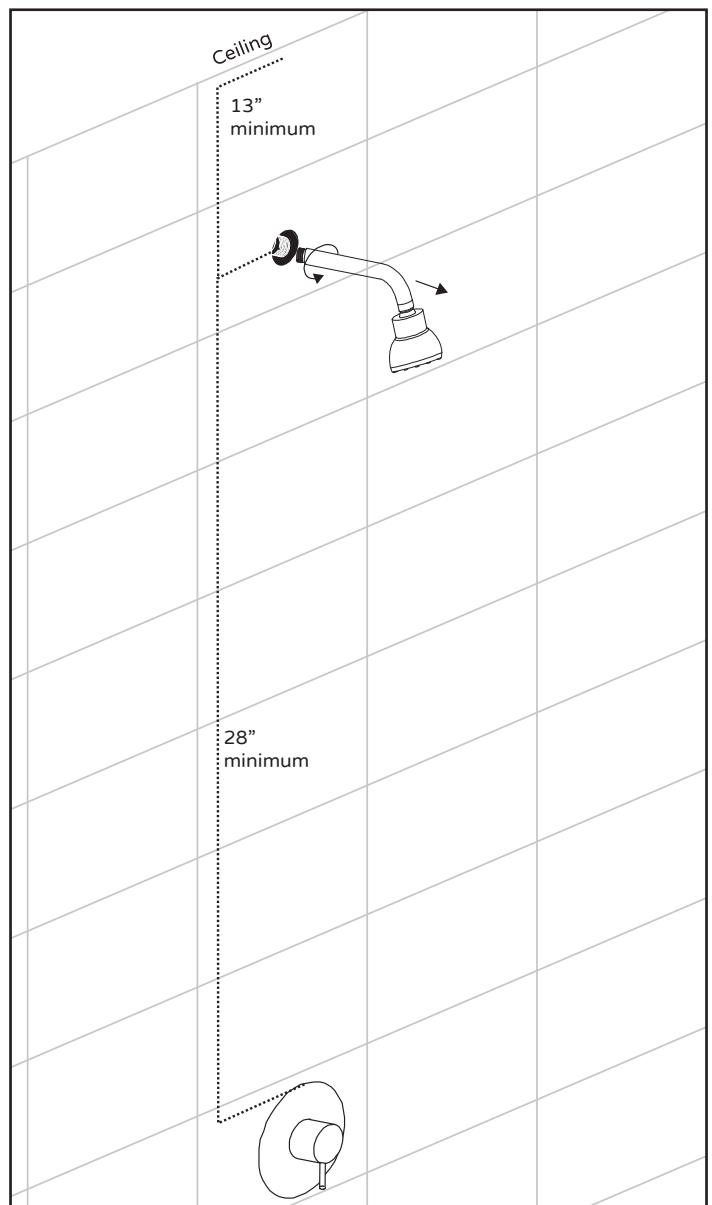

Remove existing shower arm and shower head.

Make sure distance from water outlet and mixing valve trim (NOT INCLUDED) is a minimum 28" or more.

Make sure the distance from the water outlet and the ceiling is a minimum of 13" or more.

Installation Instructions

1

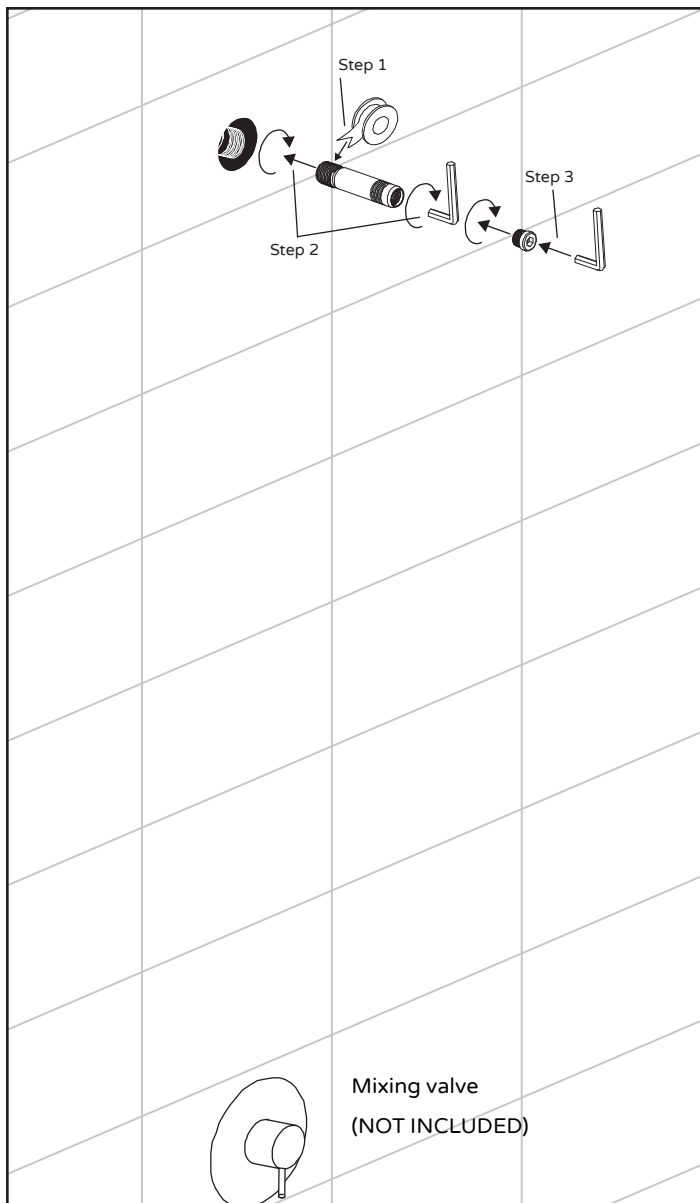

[Step 1] Apply a generous amount of PTFE (plumber's) (2) tape to end of end of nipple (4).

[Step 2]Screw nipple (4) into fitting which old shower arm was screwed into. Use allen wrench provided to secure. DO NOT OVERTIGHTEN.

[Step 3] Screw flow restrictor (5) into nipple(4). DO NOT OVERTIGHTEN.

2

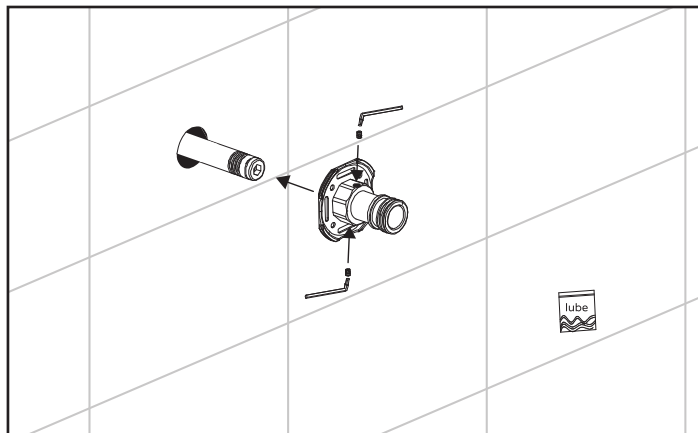

OR

2.1

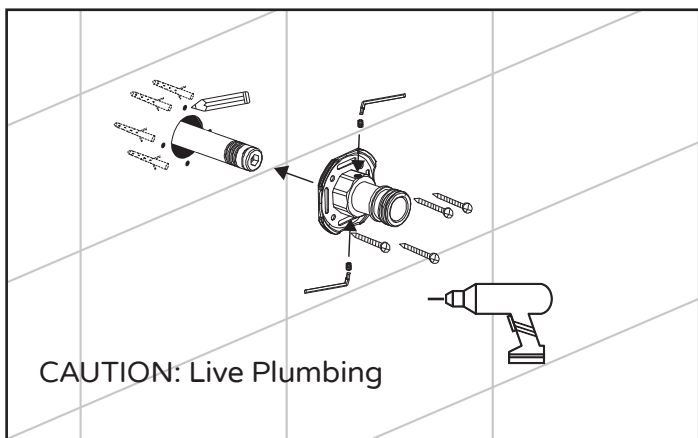

Remove set screws (2x) from Top T (15) and remove inlet fitting.

2. Slide inlet fitting (9) onto nipple (4) and secure with set screw.

OR

2.1. Mark inlet fitting (9) holes on wall before mounting. Secure with set screw (8). Drill the holes and secure with wall anchors and screws.

 USE LUBE (INCLUDED) FOR O-RING

Installation Instructions

3

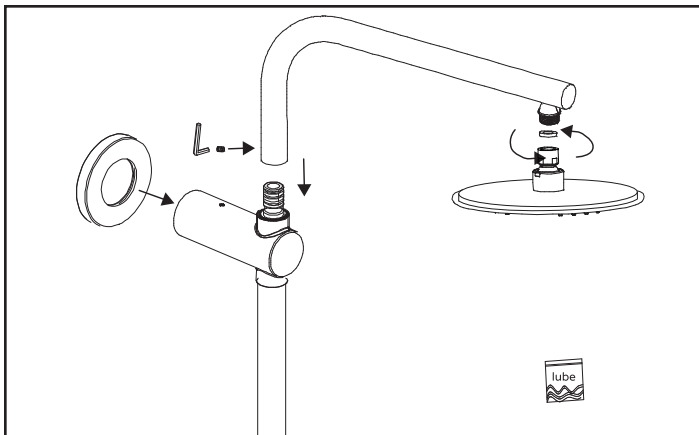

Remove plastic cover and slide shower arm (16) onto Top T (15). Connect showerhead (18). Slide in escutcheon (11). Screw showerhead (18) onto shower arm (15).



Allen wrench with 2 size ends

4

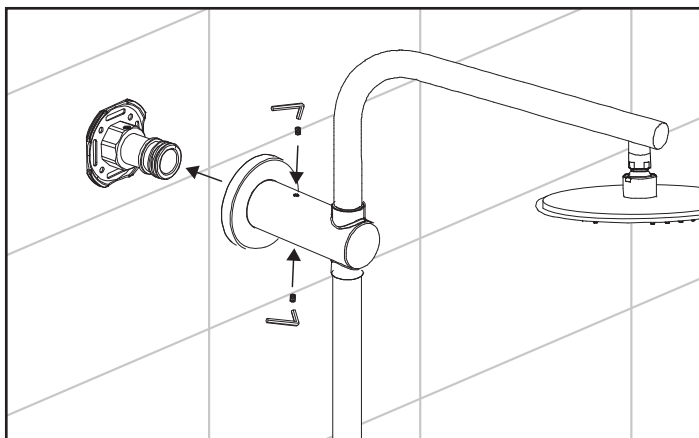

Slide in Top T (15) and secure with set screws (14).

5

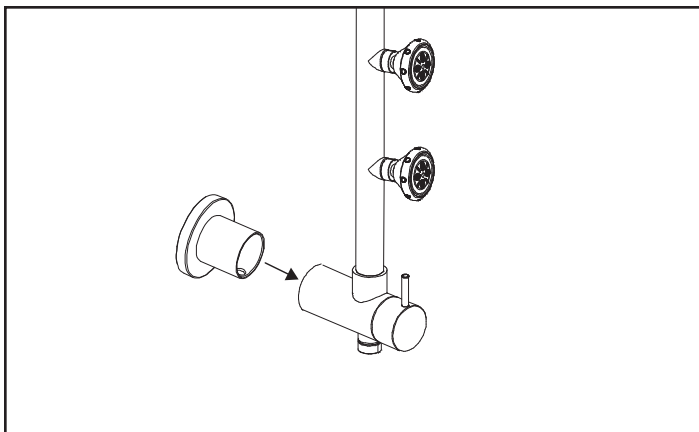

Slide in cover mount (25).

6

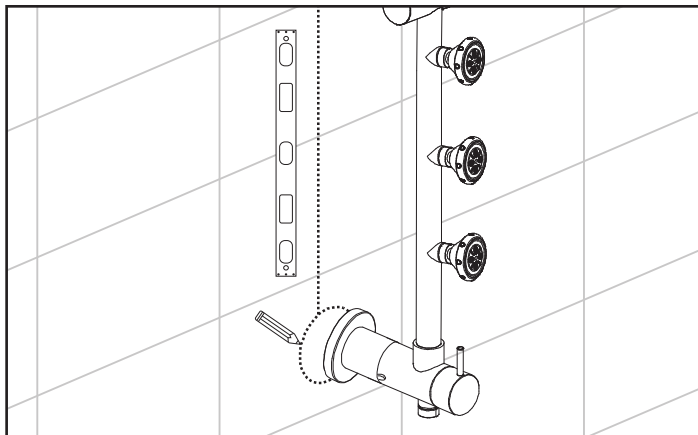

Use level to assure shower pipe is straight and mark lower diverter (24) mount location.

6.1

Drill Option

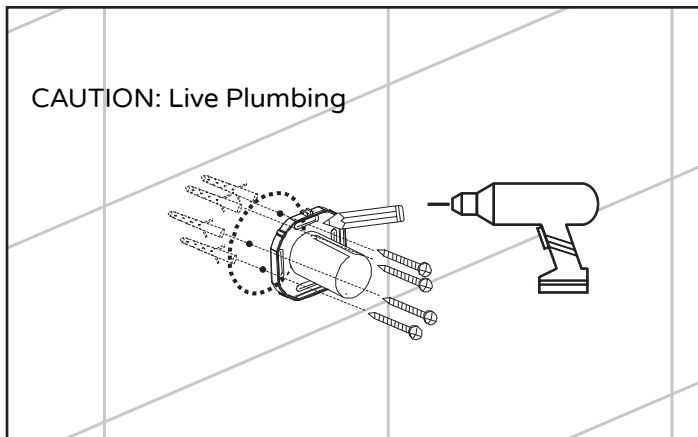

Place lower mount plate (27) on marked location and mark holes for drill option.

6.2

Drill-less Option

OR

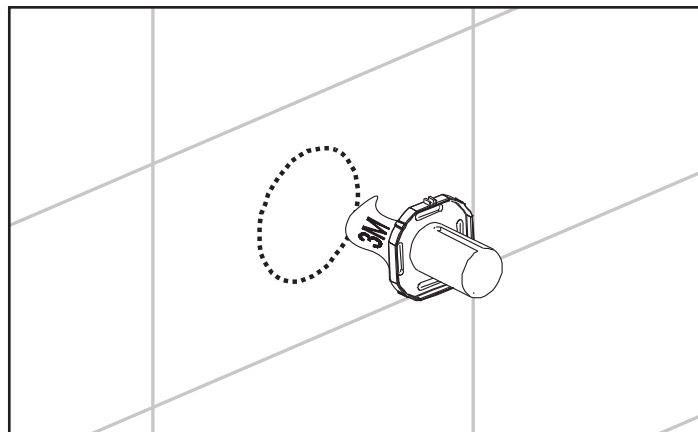

Hold for about 30 seconds to dry. Tape will be fully cured after 24 hours.

Installation Instructions

7

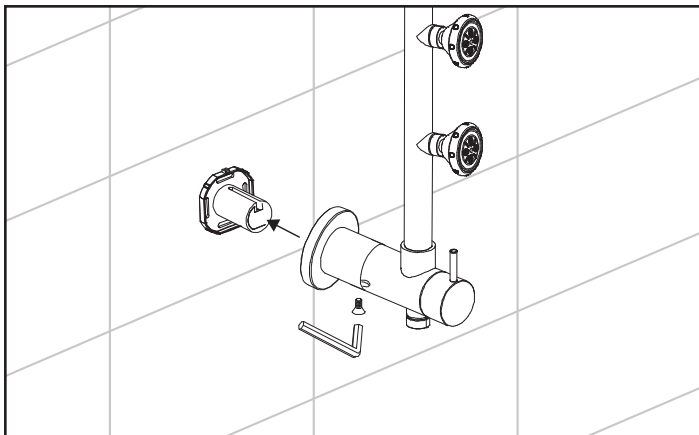

Slide bottom diverter (24) and cover mount (25) onto lower mount plate (27) and secure with set screw (26).

8

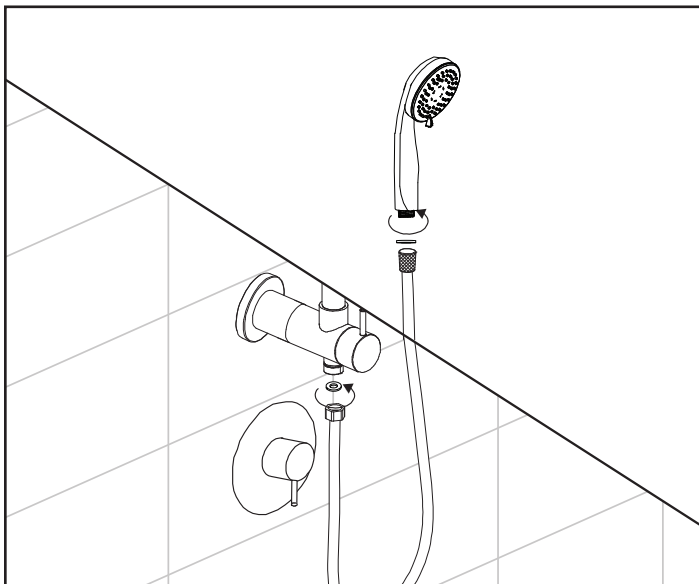

Insert washer (17) into the hex end of the hand shower hose (22). Attach hose to handshower outlet located on the bottom of the diverter (24).

Insert washer (17) into the tapered end of the handshower hose (22) and attach the handshower (21).

Place the tapered end of the hose into the handshower holder (23).

9

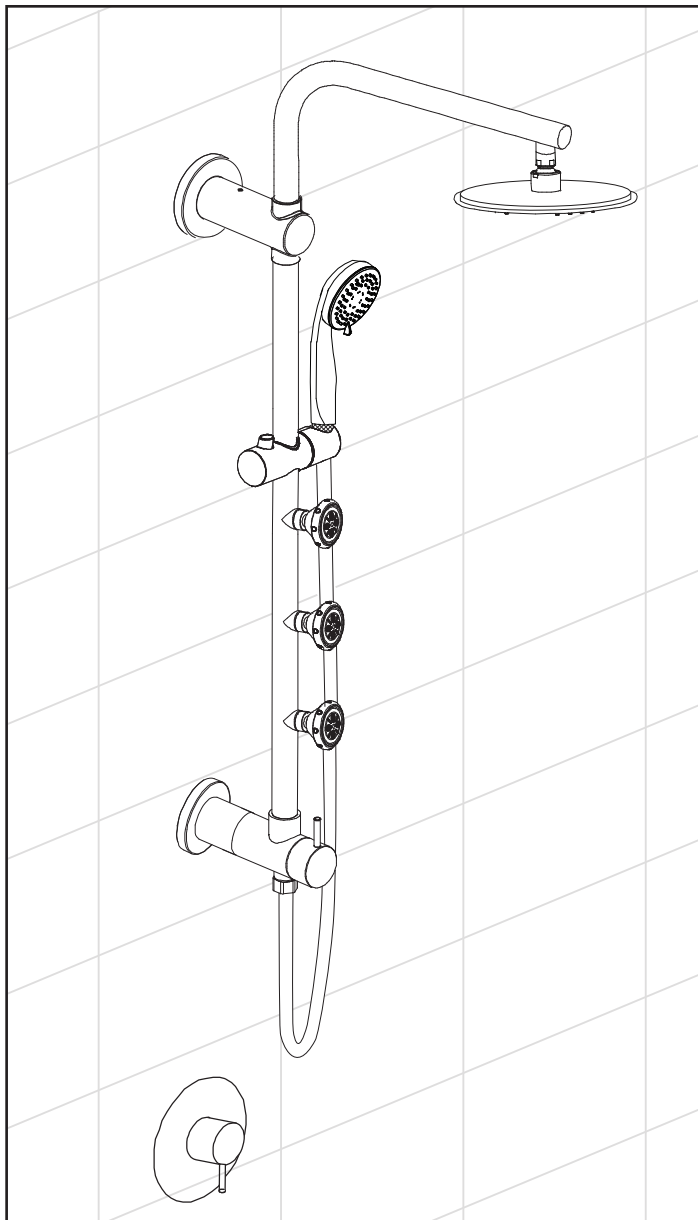

Product Fully Assembled

Usage

Diverter valve controls the showerhead, handshower, and body jets. Turn diverter clockwise to switch functions. Position between two functions to be used simultaneously.

Turn face of hand shower to switch settings.

Adjust the hand shower position by depressing the button on the hanger and sliding up or down the shower pipe.

This system is equipped with PULSE PowerSpray™ body jets, to turn off top two jets, turn the jet counter clockwise.

Always turn cold water on first to help prevent any accidental burning or scalding; especially for children and elderly.

This shower system is equipped with Spray Straight™ technology in the tips of the showerhead and hand shower. If the stream becomes obstructed from mineral deposits, simply rub the soft tips with your finger to loosen the deposits.

DO NOT use any part of the Shower System as a support device.

Care and Maintenance

To keep your Shower System looking new, wipe down after each use with a soft cotton cloth.

Protect your Shower System from hard water stains and mineral deposits by periodically using an auto spray wax.

Clean using mild liquid soap and a non-abrasive sponge or cloth. Rinse with clean water.

If the flow rate of your ShowerSpa is less than desired or reduces over time, flow restrictors located in the inlet fitting can be removed for cleaning. If further assistance is required please contact customer support at www.PulseShowerSpas.com

**Do Not Use Any Kind Of
Chemicals Or Abrasives!**

MANUFACTURER'S LIFETIME LIMITED WARRANTY

1. Defects Covered; Warranty Period: Pulse Shower Spas, Inc. ("Pulse") warrants to the original consumer purchaser who purchases this shower spa (the "Product") for use in his or her own home, that the Product will be free from defects in material and manufacturing workmanship for as long as the original consumer purchaser owns that same home. For all other purchasers (including, but not limited to purchasers for industrial, commercial and business use), the above warranty will apply for a period of 5 years from the original date of purchase.

2. Remedy: If the Product does not conform to the above warranty, Pulse, at its option, will repair or replace the Product, free of charge, or refund your purchase price. For warranty claims, please visit www.pulshower spas.com/index.php/warranty. Pulse may require that you return the Product to Pulse, shipping prepaid, in which case Pulse will provide you with a return materials authorization number (RMA). Pulse may also require that you provide evidence of the date you purchased the Product. Pulse will ship a new or repaired Product to you, at the expense of Pulse, or refund your purchase price. Service labor performed by you or others in connection with the removal or replacement of the Product will not be reimbursed by Pulse.

3. Exclusions: Pulse shall not be responsible for failure of the Product, and the above warranties will not apply, if the Product fails as a result of improper installation, improper use, modifications or repairs by anyone other than Pulse, or accident or abuse (including damage during shipment).

4. Warranty on Repairs and Replacements: For consumer purchasers who purchased the Product for home use, repaired or replacement Products will continue to be covered under this warranty for as long as he or she owns that same home. For other purchasers, repaired or replacement Products will be covered for the balance of the original warranty period.

5. No Other Warranties; Limitation of Liability: OTHER THAN THE LIFETIME LIMITED WARRANTY STATED ABOVE, PULSE DISCLAIMS ALL OTHER WARRANTIES, EXPRESS OR IMPLIED, INCLUDING BUT NOT LIMITED TO WARRANTIES OF MERCHANTABILITY AND FITNESS FOR A PARTICULAR PURPOSE, TO THE EXTENT PERMITTED BY APPLICABLE LAW. THE REMEDIES STATED ABOVE ARE YOUR SOLE REMEDIES IN CONNECTION WITH THIS WARRANTY. IN NO EVENT WILL PULSE BE LIABLE TO YOU FOR ANY DAMAGES, WHETHER DIRECT, INDIRECT, INCIDENTAL, SPECIAL OR CONSEQUENTIAL, INCLUDING BUT NOT LIMITED TO LOST PROFITS OR BUSINESS INTERRUPTION, ARISING OUT OF OR RELATING TO THE PRODUCT OR ITS USE, WHETHER UNDER A CONTRACT, WARRANTY, TORT, OR ANY OTHER CAUSE OF ACTION, EVEN IF PULSE HAS BEEN ADVISED OF THE POSSIBILITY OF SUCH DAMAGES. NOTWITHSTANDING THE TERM OF ANY LIMITED OR IMPLIED WARRANTY, OR IN THE EVENT THAT ANY LIMITED WARRANTY FAILS OF ITS ESSENTIAL PURPOSE, IN NO EVENT WILL PULSE'S ENTIRE LIABILITY EXCEED THE PURCHASE PRICE OF THE PRODUCT. SOME STATES AND PROVINCES DO NOT ALLOW THE EXCLUSION OR LIMITATION OF INCIDENTAL OR CONSEQUENTIAL DAMAGES SO THE ABOVE LIMITATIONS OR EXCLUSIONS MAY NOT APPLY TO YOU. THIS LIMITED WARRANTY GIVES YOU SPECIFIC LEGAL RIGHTS, AND YOU MAY ALSO HAVE OTHER RIGHTS WHICH VARY FROM STATE TO STATE AND PROVINCE TO PROVINCE.

